

P/N 10888

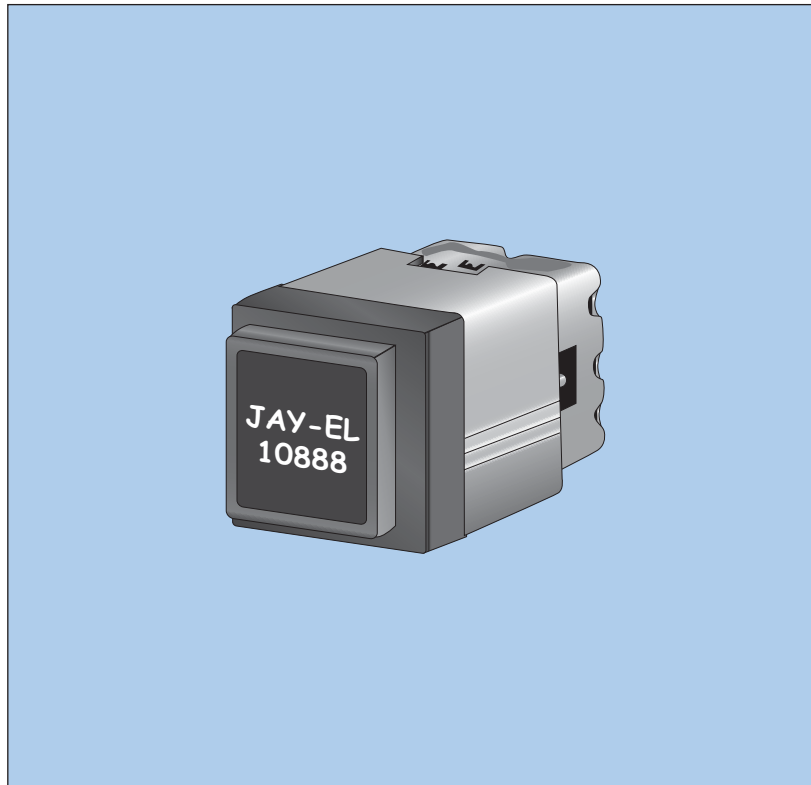

**JAY-EL**

**PRODUCTS**



**JAY-EL P/N 10888  
ILLUMINATED PUSHBUTTON SWITCH  
MEETS REQUIREMENTS OF  
MIL-S-22885**



**Ducommun**  
**Technologies**

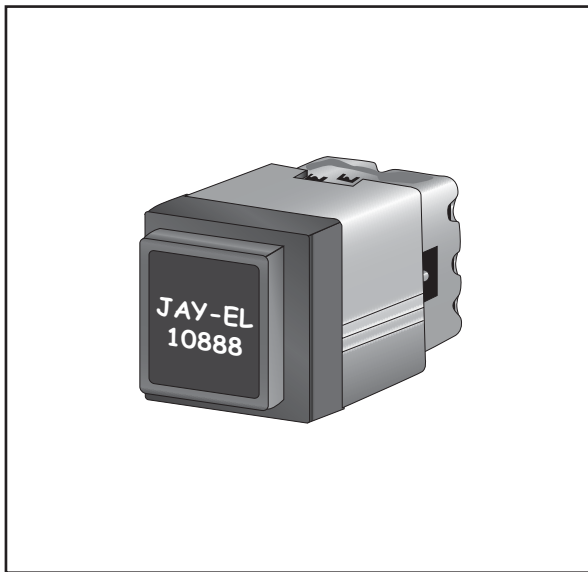

**GOLD CONTACTS**

	Sea Level and 50,000 Feet
Max. Voltage	28VDC
Max. Current	1 Amp.Res. .5 Amp. Ind

Contact Resistance:  
 3 Ohms maximum at low level load  
 10 Milliamps, 30 Millivolts  
 Low Level, 10 Milliamps, 30 Millivolts  
 Logic, 10 Milliamps, 5 Volts  
 25 Milliohms maximum in accordance with MIL-S-22885 for switch contacts and 1 OHM maximum in accordance with MIL-S-22885 for lamp contacts.

Electrical Life:  
 25,000 cycles at rated loads per Para. 3.6.24 of MIL-S-22885C.

**ENVIRONMENTAL**

In accordance with MIL-S-22885 & MIL-S-901  
 Temperature: High + 85° C Low -55° C  
 Explosion: Per Mil-Std-810, Method 511 Procedure II  
 Humidity: Per Mil-Std-202, Method 106  
 Vibration: 10-2000Hz @ 0.6DA or 15 G (Peak) whichever is less.  
 Shock: 75G's, 6millseconds, Half sine & MIL-S-901C  
 EMI: Per Mil-Std-285  
 SPLASH PROOF: MIL-STD-108

**MECHANICAL**

Actuation Force: To total travel  
 Unsealed 2 to 5 pounds  
 Sealed 2 to 5.5 pounds  
 To switch contact transfer: 1 to 3.5 pounds.

**ENGINEERING SPECIFICATIONS**

**ELECTRICAL**

Switch Contacts:  
 Silver alloy contacts are standard. Gold contacts are recommended for reliable low level switching below 1.0 amperes.

Basic Switch contacts per Mil-S 8805/101  
 Switch Ratings:

**SILVER CONTACTS**

	Sea Level, 28VDC	50,000 feet, 28VDC
Load	NO or NC	NO or NC
	(Amperes, maximum)	(Amperes, maximum)
Resistive	8.0	8.0
Inductive	5.0	3.0
Lamp	1.0	--

- 1/ Inrush, 10:1 for 20 milliseconds maximum.
- 2/ Minimum conditions are dependent on use and atmospheric conditions.  
 Contact Jay-El for detailed application information.

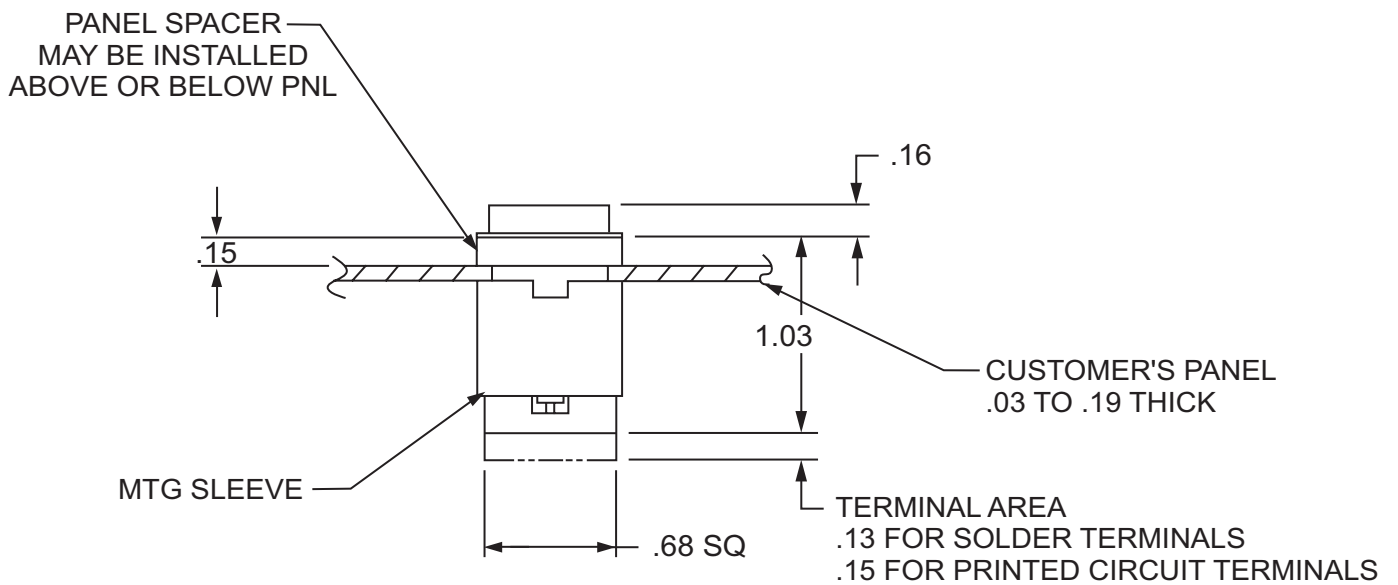
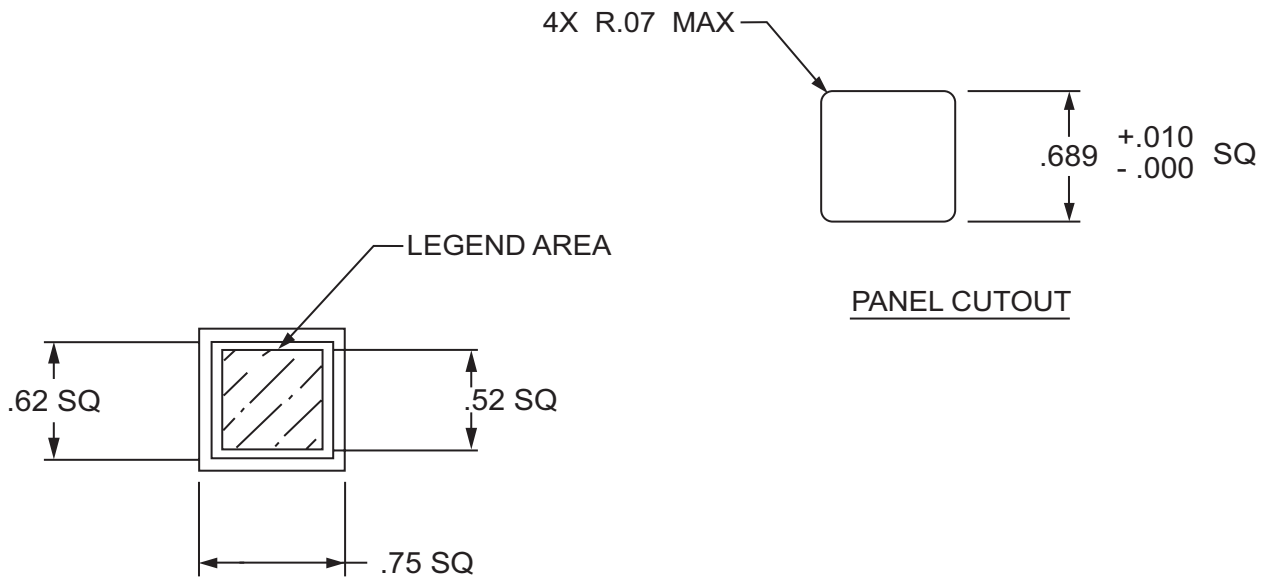

UNSEALED SWITCH AND PUSHBUTTON ASSY

MOUNTING TYPE I

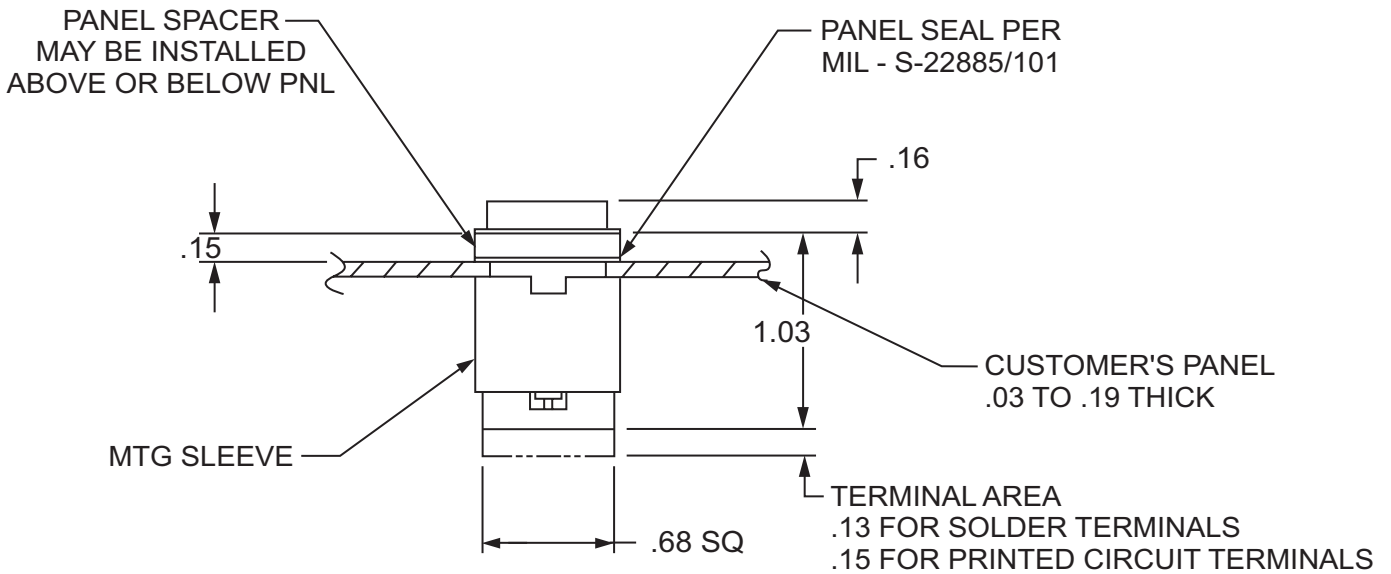
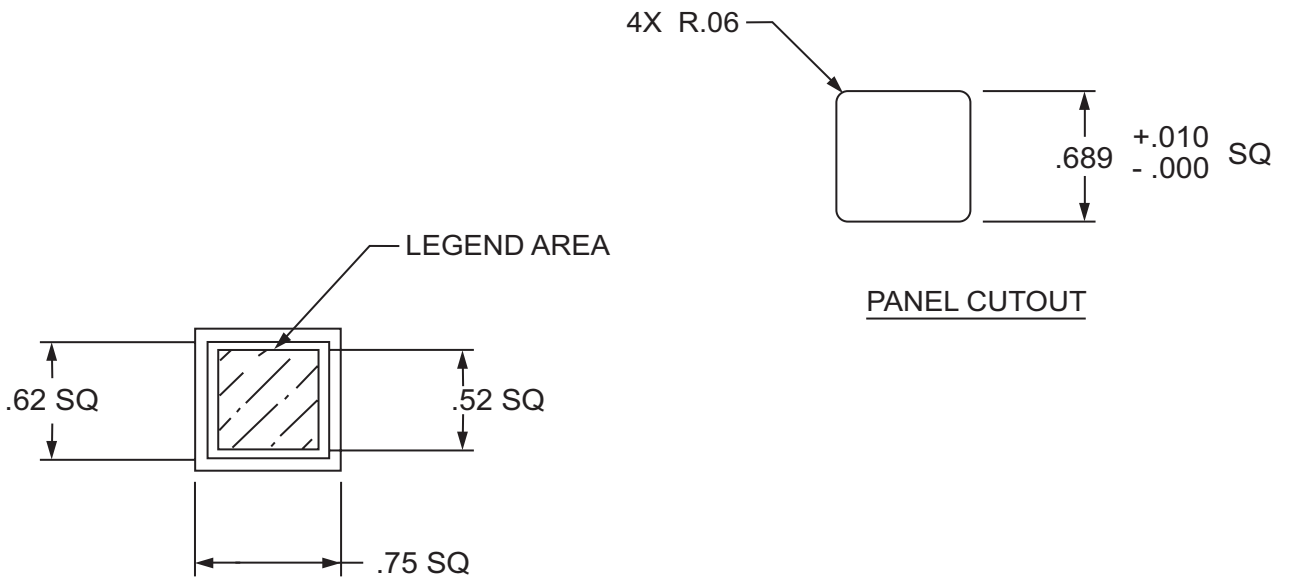

INTERNAL-SEAL SWITCH AND PUSHBUTTON ASSY (DRIP PROOF)

MOUNTING TYPE I

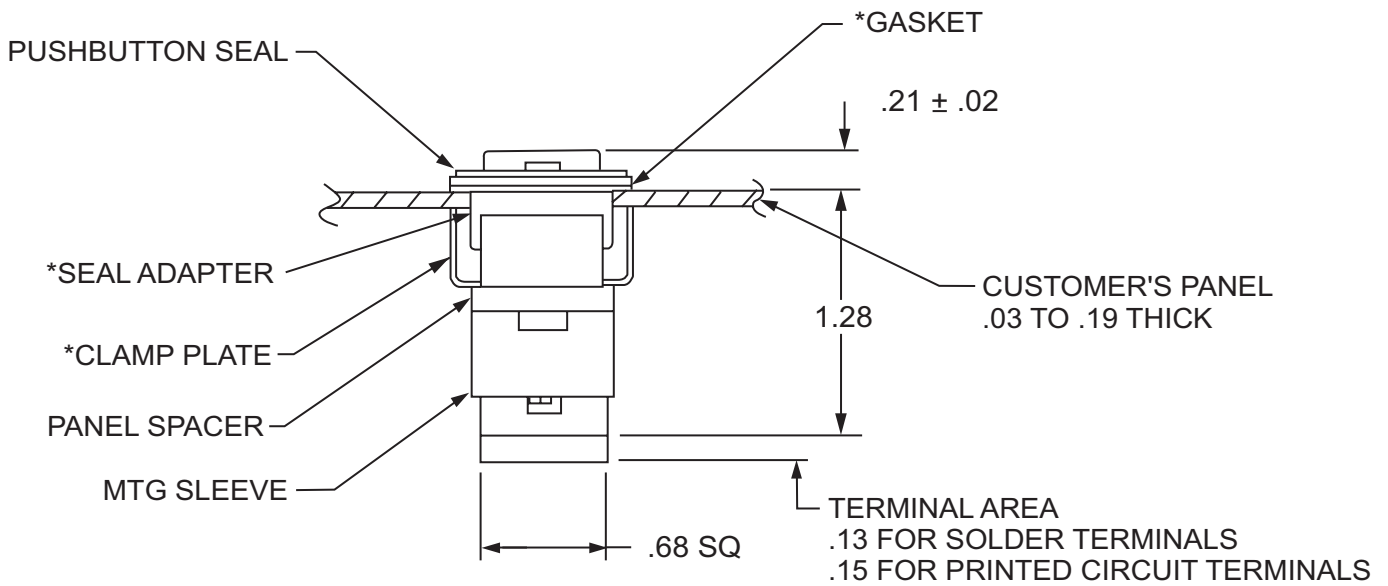
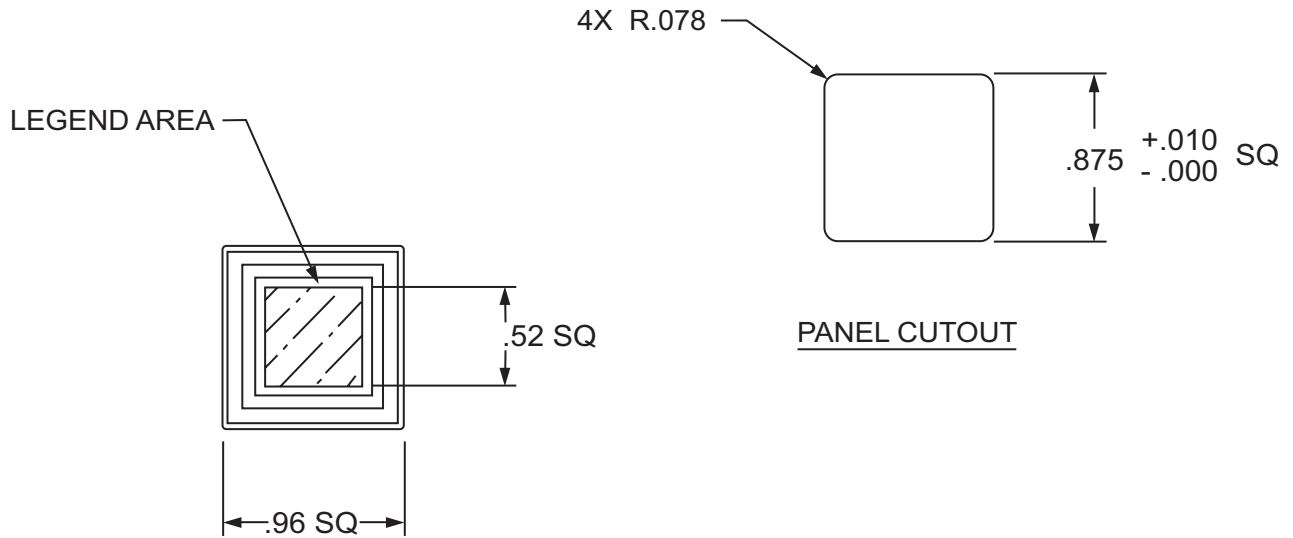

INTEGRALLY-BONDED SEALED PUSHBUTTON AND SWITCH ASSY (SPASHPROOF)

\* SEAL KIT: AVAILABLE AS KIT, PN 530649 - [ ] (-1 IS BLACK FINISH; -2 IS BLACK FINISH - EMI)

MOUNTING TYPE I

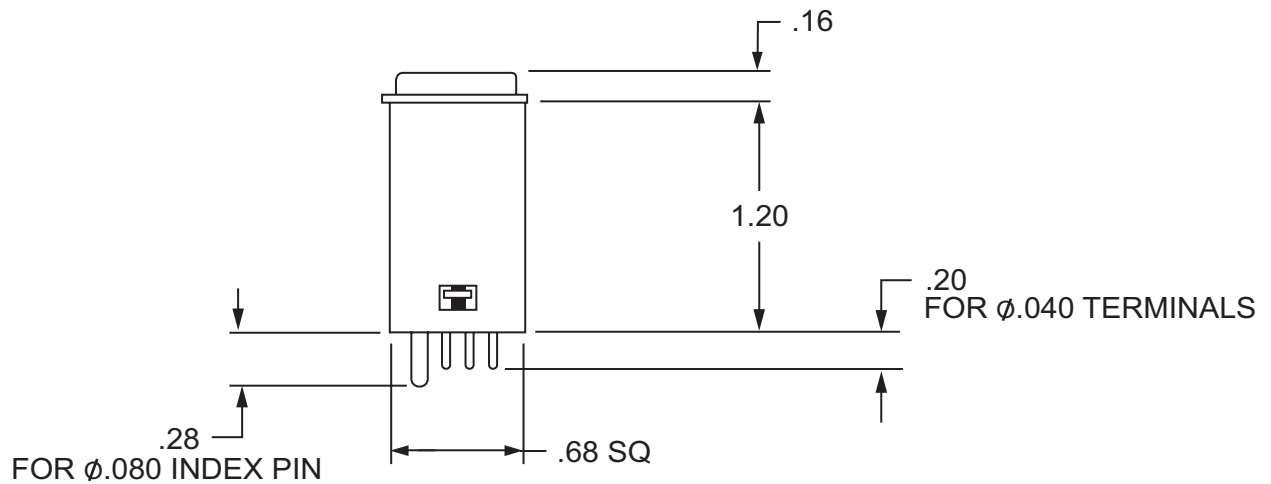
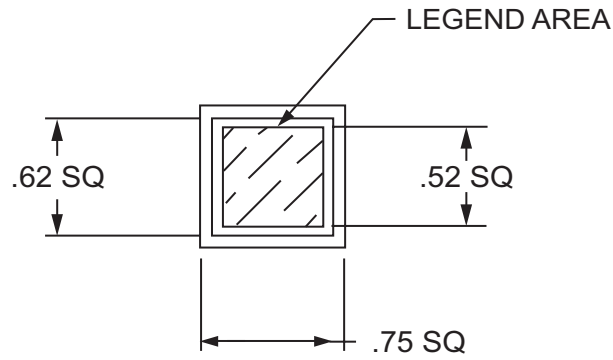

UNSEALED SWITCH AND PUSHBUTTON FOR PLUG-IN MATRIX

## MOUNTING TYPE III

## COMMON GROUND LAMP CIRCUIT

WITH SOLDER TERMINALS OR PRINTED CIRCUIT TERMINALS

### INDICATOR ONLY

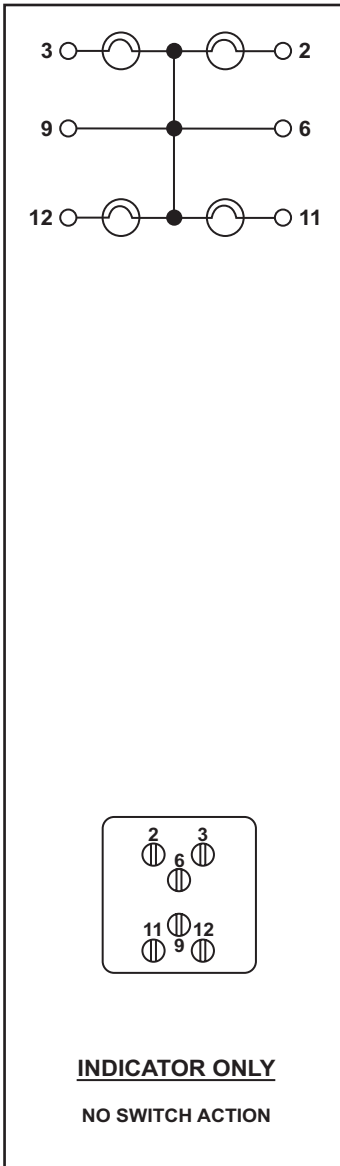

### SPDT

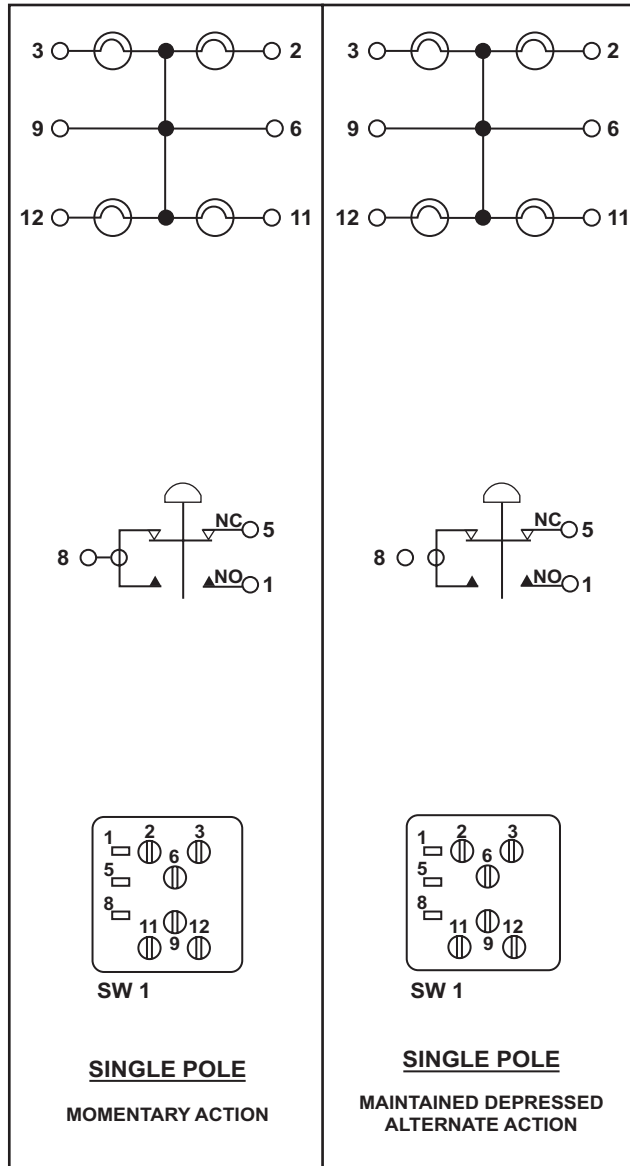

### DPDT

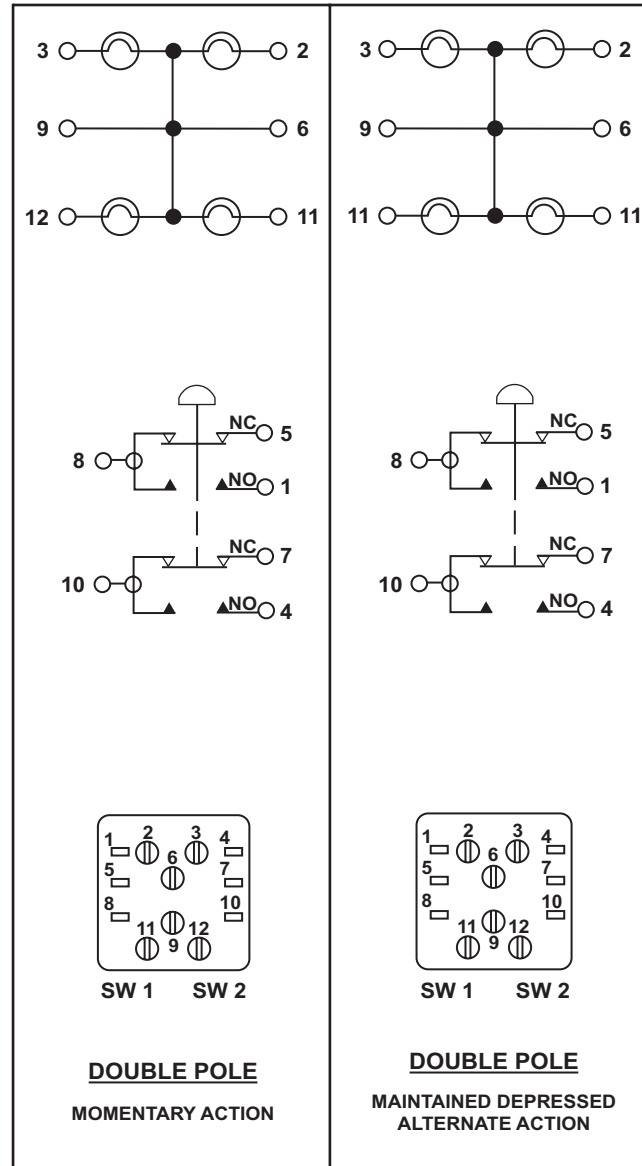

P/N 10888



**JAY-EL**

**PRODUCTS**

## SPLIT GROUND LAMP CIRCUIT WITH SOLDER TERMINALS OR PRINTED CIRCUIT TERMINALS

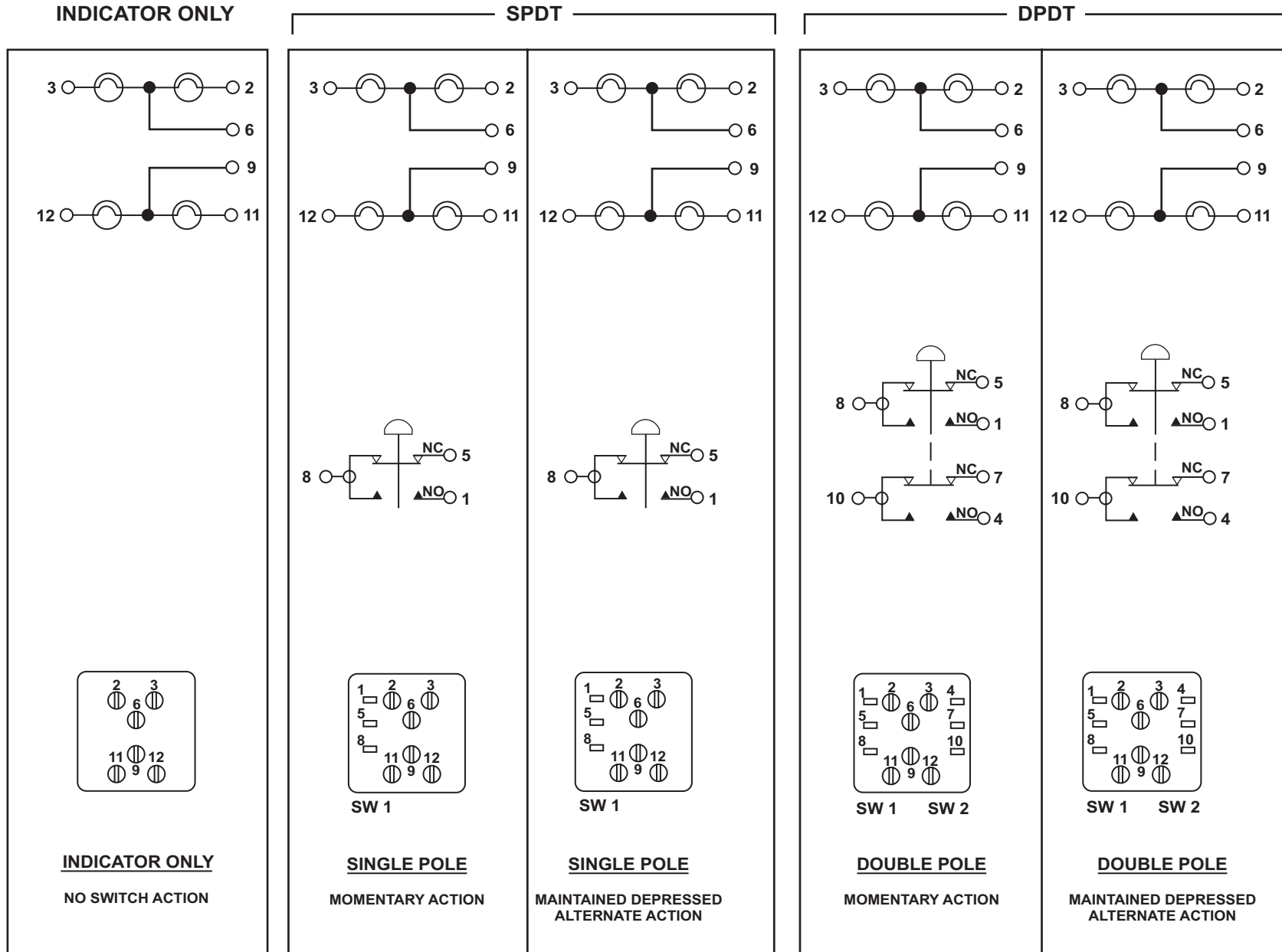



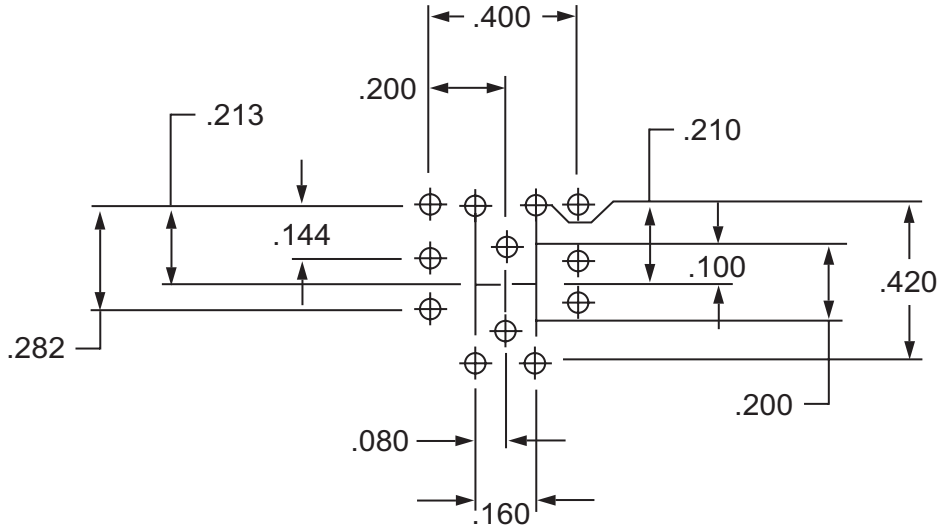

TERMINAL LOCATIONS  
(SOLDER OR PRINTED CIRCUIT TERMINATIONS)

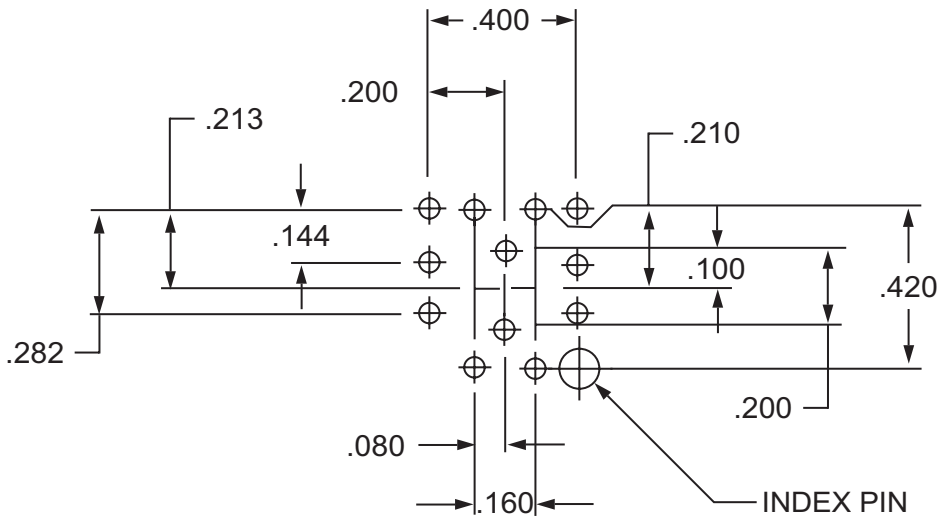

TERMINAL LOCATIONS  
(PLUG-IN SWITCH, MATRIX MOUNTED TERMINATIONS)  
TYPE III



**ORDERING PROCEDURE** - Fill out Preliminary Product Specification using Tables below and submit to Jay-El for Customer Code assignment.

TABLE 1 BASIC P/N	TABLE 2 MOUNTING TYPE	TABLE 3 BEZEL COLOR	TABLE 4 SPLIT GROUND	TABLE 5 EMI	TABLE 6 SEAL	TABLE 7 RETAINED PUSHBUTTON
10820	I III	BLACK CRES	YES NO	YES NO	SPLASHPROOF DRIP-PROOF NO	YES

TABLE 8 PUSHBUTTON STYLE	TABLE 9 SWITCH POLES	TABLE 10 CONTACTS	TABLE 11 SWITCH ACTION	TABLE 12 UNLIGHTED BACKGROUND COLOR	TABLE 13 DISPLAY DATA
STANDARD	O INDICATOR 1 1 SPDT 2 2 SPDT	(ABOVE 1 AMP) S SILVER CONTACTS  (BELOW 1 AMP) G GOLD CONTACTS	O INDICATOR M MOMENTARY D MAINTAINED DEPRESSED ALTERNATE	BLK BLACK DW DIFFUSED NG NEUTRAL GRAY R RED A AMBER Y YELLOW G GREEN B BLUE	TO BE SPECIFIED ON PRELIMINARY FORM

TABLE 14 * LIGHTED COLOR	TABLE 15 * * DISPLAY TYPE	TABLE 18 CHARACTER SIZE AND PLACEMENT	TABLE 17 LAMPS
C CLEAR R RED A AMBER Y YELLOW G GREEN B BLUE DW DIFFUSED WHITE WL WHITE LIGHT NG NUETRAL GRAY AG AVIATION GREEN AY AVIATION YELLOW AG1 AVIATION GREEN 1 B1 BLUE 1	<ol style="list-style-type: none"> <li>BLACK CHARACTERS ON DIFFUSED WHITE BACKGROUND. BACKGROUND ILLUMINATES IN COLOR.</li> <li>REPLACED BY DISPLAY TYPE 7.</li> <li>UNREADABLE BEFORE LIGHTED. OPAQUE CHARACTERS ON NUETRAL GRAY ILLUMINATING BACKGROUND.</li> <li>ILLUMINATING CHARACTERS ON BLACK BACKGROUND. CHARACTERS SHALL NOT APPEAR ILLUMINATED IN UNLIT CONDITION.</li> <li>CONTRASTING OPAQUE CHARACTERS ON ILLUMINATING COLORED BACKGROUND. BLACK CHARACTERS ON YELLOW OR AMBER BACKGROUND. WHITE CHARACTERS ON ALL OTHER COLORS.</li> <li>DISPLAY TYPES NOT COVERED BY THIS TABLE SHOULD BE SPECIFIED BY A NOTE ON PURCHASE ORDER OR MAY BE SPECIFIED ON JAY-EL CUSTOMER SPECIFICATION.</li> <li>WHITE CHARACTERS ILLUMINATE IN COLOR ON BLACK BACKGROUND.</li> <li>SUNLIGHT READABLE ILLUMINATING CHARACTERS ARE HIDDEN BEFORE LIGHTED. BLACK BACKGROUND. CHARACTERS ARE VISIBLE IN DIRECT SUNLIGHT. (10,000FC) WHEN LIGHTED.</li> <li>SUNLIGHT READABLE ILLUMINATING BLACK BACKGROUND IS HIDDEN BEFORE LIGHTED. BLACK OPAQUE. CHARACTERS ARE VISIBLE IN DIRECT SUNLIGHT ( 10,000FC) WHEN LIGHTED.</li> </ol>	SEE CHARACTER INFORMATION CHARTS	T1 NO. VOLTS 3071 5 718 5 6839 28 OR EQUIV

**\* \* DISPLAY TYPE 8 AVAILABLE WITH .012 STROKE WIDTH ONLY**

**NOTES:**

- \* AG OR AY SHOULD BE SPECIFIED WHEN GREEN OR YELLOW IS TO MEET MIL - C - 25050 AY APPEARS AMBER WHEN ILLUMINATED.
- \* B1 AND AG1 SPECIAL HIGH BRIGHT BLUE & GREEN RECOMMENDED FOR DISPLAY TYPE 8.



**CHARACTER INFORMATION**  
(HORIZONTAL DIRECTION ONLY)

To obtain more characters per line other type fonts are available.  
Contact Jay-El for further information.

DISPLAY TYPE 1 THRU 7	LEGEND SEGMENTS *				CHARACTERS PER LINE			NUMBER OF LINES	
					SEGMENT	SEGMENT	SEGMENT	SEGMENT	SEGMENT
	CONDENSED BLOCK	SIZE	STROKE	HEIGHT	-1	-2-3	-4-5-6	-1-4-5	-2-3-6
<p>.53 SQ. LEGEND AREA</p> <p>STANDARD .62 SQ.</p>	JAY-EL PRODUCTS INC.	-1	.010	.072	8	8	3	5	2
	JAY-EL PRODUCTS INC.	-2	.012	.087	7	7	3	4	2
	JAY-EL PRODUCTS INC.	-3	.015	.109	6	6	3	3	1
	JAY-EL PRODUCTS	-4	.018	.125	5	5	2	3	1
	JAY-EL PRODUCTS	-5	.020	.145	4	4	2	3	1
	JAY-EL PRODU	-6	.025	.175	4	4	1	2	1
	JAY-EL PRO	-7	.035	.222	3	0	1	2	0
	JAY-EL P	-8	.040	.290	2	0	0	1	0

* DISPLAY TYPE 8 AND 9	LEGEND SEGMENTS				CHARACTERS PER LINE			NUMBER OF LINES	
					SEGMENT	SEGMENT	SEGMENT	SEGMENT	SEGMENT
	FUTURA MEDIUM CONDENSED	SIZE	STROKE	HEIGHT	-1	-2-3	-4-5-6	-1-4-5	-2-3-6
<p>.48 SQ. LEGEND AREA</p>	JAY-EL PRODUCTS INC.	-1	.012	.072	11	11	5	5	2
	JAY-EL PRODUCTS INC.	-2	.012	.087	9	9	4	4	2
	JAY-EL PRODUCTS INC.	-3	.012	.109	7	7	3	3	1
	JAY-EL PRODUCTS	-4	.012	.125	6	6	3	3	1
	JAY-EL PRODUCTS	-5	.012	.145	5	5	2	3	1
	JAY-EL PRODU	-6	.012	.175	4	4	1	2	1
	JAY-EL PRO	-7	.012	.222	3	3	0	2	0

\* **BASIC INFORMATION** Legend area .480 square for full face on all push button styles.  
.230 x .480 for 1/2 section ( may be used with combination of other Display Types. )



A Manufacturer of Quality Switches for over 40 years  
**23301 Wilmington Ave., Carson, CA 90745 USA**  
**Phone: (310) 513-7200 - FAX: (310) 513-0741**

Federal Mfg. Code No. 08719