

MARK 7
P/N 10800

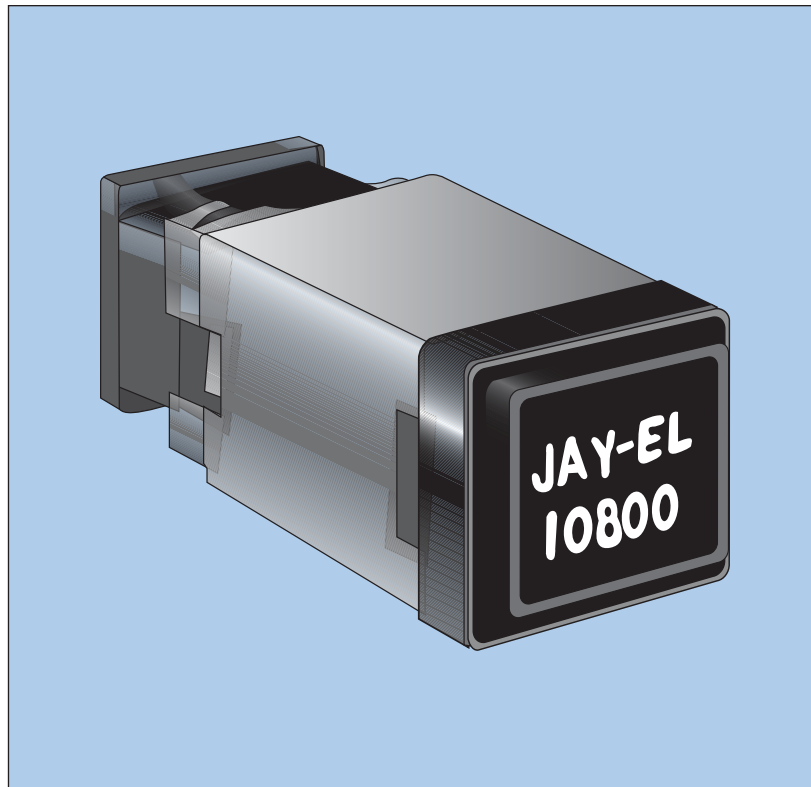

JAY-EL

PRODUCTS



JAY-EL MARK 7 P/N 10800
ILLUMINATED PUSHBUTTON SWITCH
CONFORMS TO QPL MIL-S-22885/94



Ducommun
Technologies



**JAY-EL MARK 7
P/N 10800
ILLUMINATED PUSHBUTTON SWITCH**

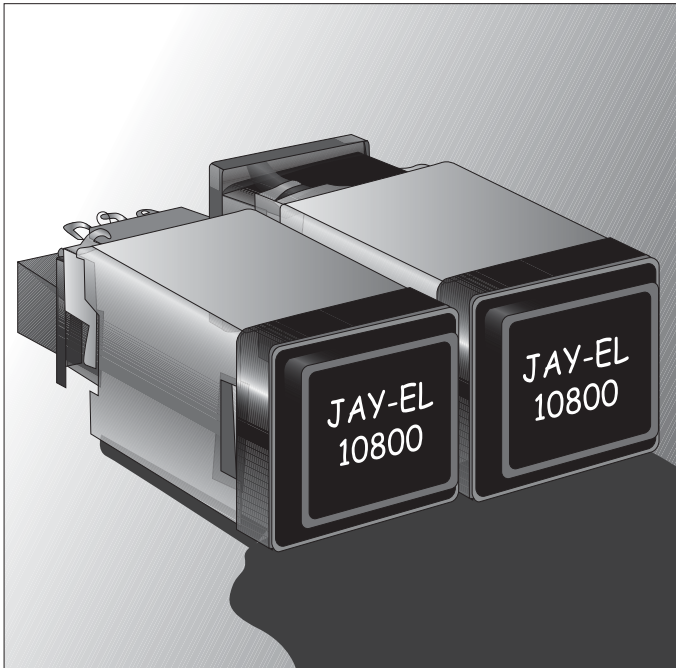

COMPACT SIZE

The Mark 7 is designed for maximum use of available panel space. Two types of mountings are available, both having .688 square chassis.

The Type I switch has a standard bezel, mounting sleeve and self contained mounting hardware. It mounts on .750 centers.

Type II is designed for dense matrix mounting to customer requirements. Mountings in this manner allows for centers of .689. Jay-El will Design and supply brackets or customer may specify.

SEVERAL PUSHBUTTON STYLES AVAILABLE

From standard with .53 square legend area to the largest with .64 X .89 legend area.

Jay-El can provide P/N 10800 switches and indicators with NVIS compatible lightning.

*ALL INFORMATION PUBLISHED IN THIS CATALOGUE IS EFFECTIVE AT TIME OF PUBLICATION AND IS SUBJECT TO CHANGE WITHOUT NOTICE.

DESIGN FEATURES

Designed to meet all of the requirements of Mil-S-22885. The Mark 7 is available with up to 2 pole, momentary switching and 4 lamp circuits as a single switch or supplied in a matrix assembly to customer specification. The minimum behind panel space used by the Mark 7 allows for the electronics to be packaged in the matrix itself.

ENVIRONMENTAL SEALING - MIL-STD-108

The Mark 7 can be supplied with an integral seal which has passed Splash Proof requirements to Mil-Std-108, High Shock to Mil-Std-901C and Mil-S22885. This is available for pushbutton styles B, C and D. See Page 7.

Also available for the standard pushbutton only is a drip proof external area. See Page 5.

The Mark 7 can be supplied with the rear switch modules and actuator sealed against all contaminants. This is important for low level dry circuit switching applications or applications where the switches are being used in a heavy salt atmosphere.

MOUNTING

Type I incorporates a mounting sleeve with rotating cams and a removable spacer to allow the switch bezel to be mounted flush with a .220 thick edge lighted panel.

Type II contains no mounting hardware and is supplied with or without mounting brackets.

These mounting brackets can be of practically any configuration and are to customer requirements. Both mounting methods afford secure shock and vibration proof mounting.

SUNLIGHT READABLE DISPLAYS

The Mark 7 P/N 10800 is available with a legend that is hidden before lighted and provides lighted characters readable in direct sunlight (10,000 FC). It is designated as Display Type 8. This display type utilizes maximum lighted contrast enhancing techniques.

Available with T-1 or T-1 $\frac{3}{4}$ based lamps. Most efficient Display Type 8 is with the "T" type pushbutton using T-1 lamps. This "T" type pushbutton eliminates high legend surface temperatures and can provide power saving up to 70% with no loss of luminance. Luminances far exceed requirements of MIL-STD-411 when using .15MSCP lamps.

Details for legend information and viewing area on Page 11.



ENGINEERING SPECIFICATIONS

ELECTRICAL

Switch Contacts:
Silver Alloy contacts are standard. Gold contacts are recommended for reliable low level switching below 1.0 amperes.

Switch Ratings:

SILVER CONTACTS Maximum 2/

Load	Sea Level		50,000 FT 28VDC
	28VDC	115VAC, 60Hz	
Resistive	7.5 Amps	5.0 Amps	4.0 Amps
Inductive	5.0 Amps	3.5 Amps	2.5 Amps
Lamp 1/	1.0 Amps	1.0 Amps	1.0 Amps

1/ Inrush. 10:1 for 20 milliseconds maximum.
2/ Minimum conditions are dependent on use and atmospheric conditions. Contact Jay-El for detailed application information.

GOLD CONTACTS

	Sea Level and 50,000 Feet	Maximum Contact Res. OHM
Max. Voltage	28VDC	.025
Max. Current	1 Amp.Res. .5 Amp.Ind.	.025
Min. Current	5 Microamps	50
Min. Voltage	15 Millivolts	50

Contact Resistance:

25 Milliohms maximum in accordance with MIL-S-22885 for switch contacts and 1 OHM maximum in accordance with MIL-S-22885 for lamp contacts.

Electrical Life:

25,000 cycles at rated loads per Para. 3.33 of MIL-S-22885C.

Lamp Type:

T-1^{3/4} midget flange base incandescent is standard.

Available on special order:

T1^{3/4} Neon (External Ballast 10 K^Ω minimum)

T1 sub-midget flange base with special pushbutton modifications.

T-1^{3/4} midget flange base LED (Recommended for back lighting only)

MECHANICAL

Actuation force: Unsealed 1.5 ± .5 pounds(standard)
Sealed 2.5 ± .7 pounds

Actuation travel: .062 ± .025 inches

Push button extraction force: 1 to 4 pounds

Mechanical life: 1000,000 cycles minimum

Weight - 1.3 ounces maximum. (One pole switch with standard pushbutton.)

ENVIRONMENTAL

Temperature: High +85°C Low -55° C
Explosion: Per Mil-Std-810, Method 511, Procedure II
Humidity: Per Mil-Std-202 Method 106
Vibration 10-2000Hz @ 0.6DA or15G (Peak) whichever is less.
Shock: 75G's, 6milliseconds, Half sine & MIL-STD-901C
EMI: Per Mil-Std-285
Basic switch contacts per Mil-S-8805/101

SWITCH CONTACT SCHEMATIC

Ref: 2 pole unit shown

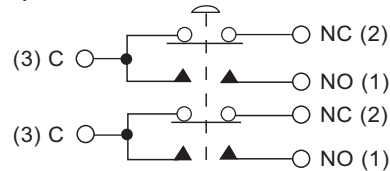

LAMP TERMINATION

*Lamp schematics indicate lamp positions as as viewed from front of unit.

For two color full face, all divided legends are supplied with lamps in all four positions.

MOMENTARY AND INDICATOR

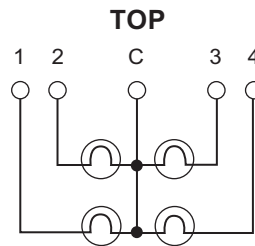

SPLIT GROUND

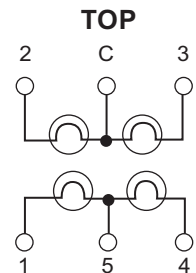

When split ground switches or indicators are required housings must be rotated 90° to right to accommodate vertically divided, or 3 way divided legend displays.

Full face legend display is supplied with lamps in the upper left and lower right positions. Other positions supplied with reflectors.

Lamps in all four positions for Display Type 8.

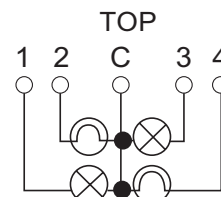

Tolerances: Unless otherwise specified - Fraction ± 1/32", .XX±.01, XXX ± .005



MAJOR OUTLINE DIMENSIONS

STANDARD INDICATOR & ONE POLE SWITCH

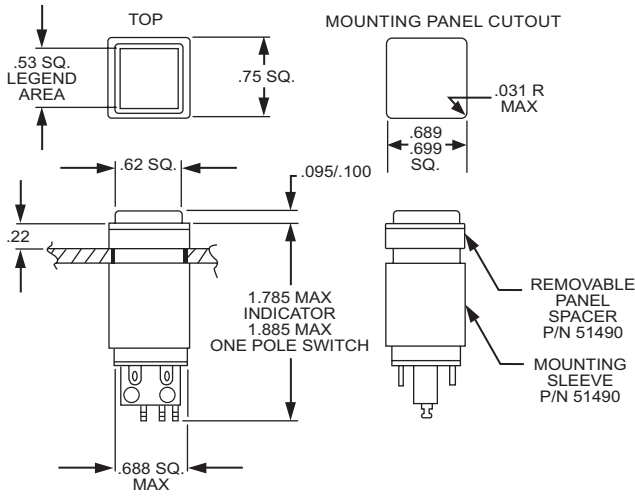

PRINTED CIRCUIT TERMINATIONS

INDICATOR & ONE POLE SWITCH

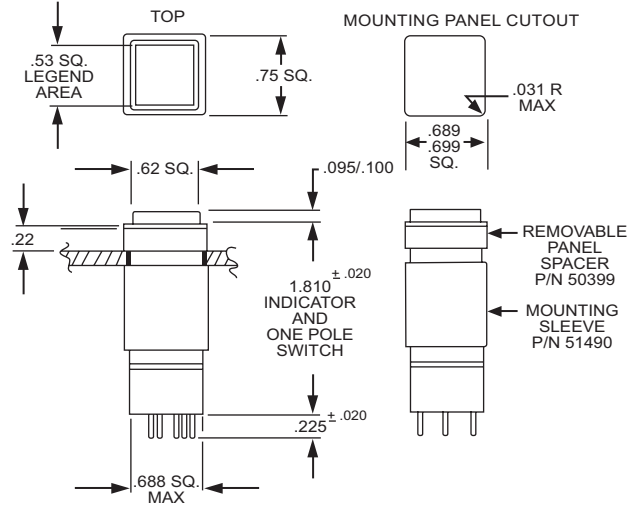

TWO POLE SWITCH

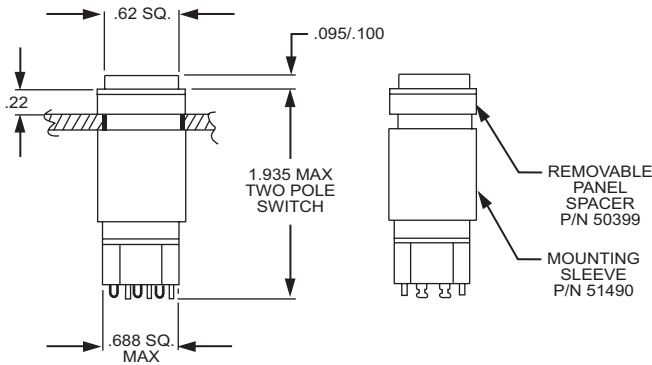

TWO POLE PC TERMINATION

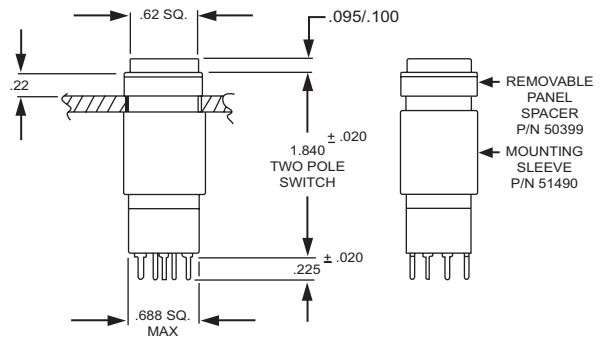

PUSHBUTTON HEIGHT

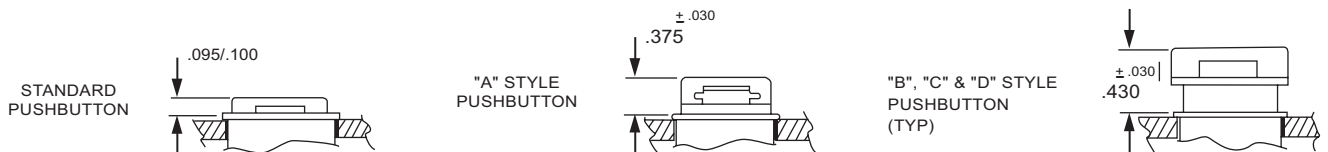

REAR VIEW

ONE POLE

TWO POLE

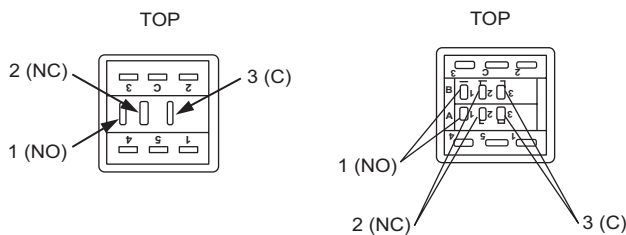

Terminal 5 used for split ground only.

REAR VIEW

ONE POLE

TWO POLE

TERMINAL LOCATIONS FOR P.C. TERMINALS (ONE POLE SWITCH OR INDICATOR ONLY)

TERMINAL LOCATIONS FOR P.C. TERMINAL (TWO POLE SWITCH)

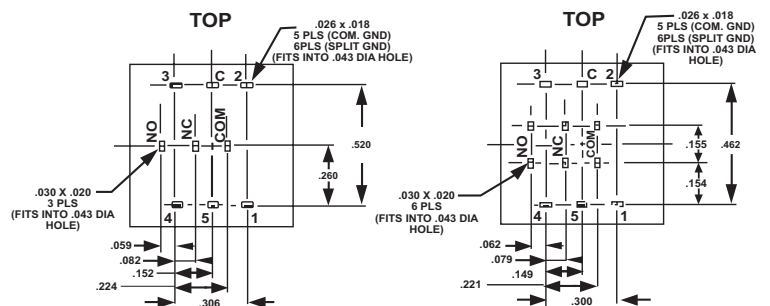



MAJOR OUTLINE DIMENSIONS

PUSHBUTTON STYLES (UNSEALED)

Standard

Standard pushbutton style will be supplied unless otherwise specified.

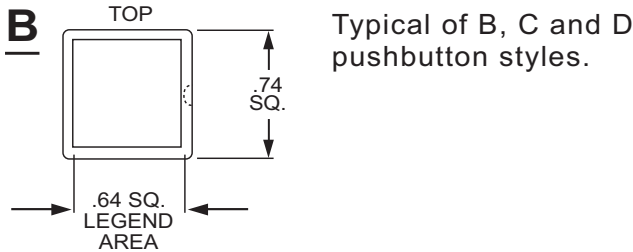
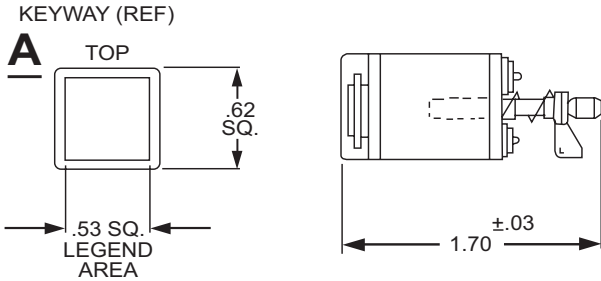
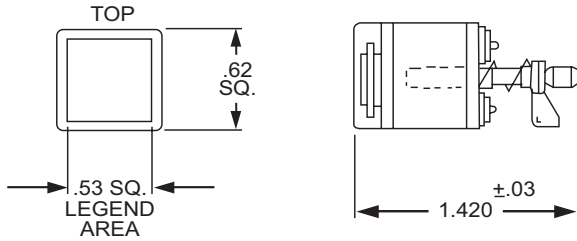

Typical of B, C and D pushbutton styles.

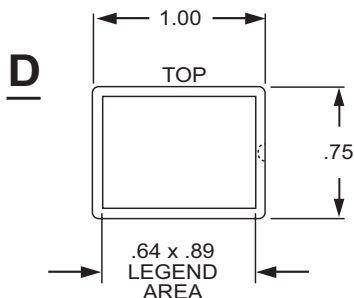
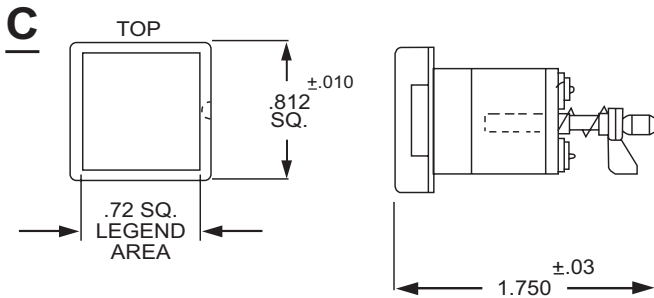

ACCESSORIES

Standard Pushbutton Only

SWITCH GUARD P/N 51056

Spring loaded clear polycarbonate switch guard.

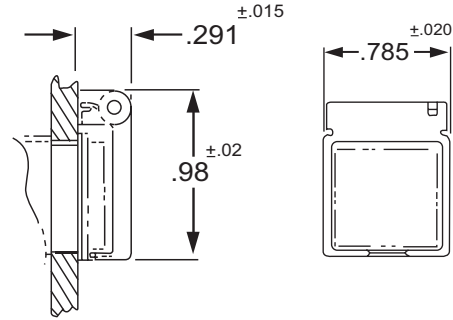

RUBBER BOOT KIT P/N 50682

- C-1 (Clear w/EMI)
- BLK-2 (w/o EMI)
- BLK-1 (w/EMI)

Flush mounted black silicone rubber boot with clear nylon window, for sand, dust and moisture protection. For standard pushbutton only.

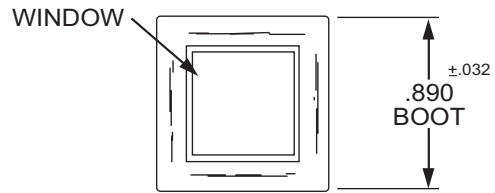

RUBBER BOOT KIT P/N 50680

Available for edge lit panel mounting.

SWITCH GUARD P/N 50632

Spring loaded clear polycarbonate switch guard to use with P/N 50682 boot.

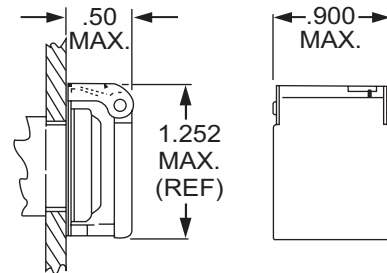

EMI SHIELDING

Welded 300 Series stainless steel grounding wipers provide chassis ground for EMI.

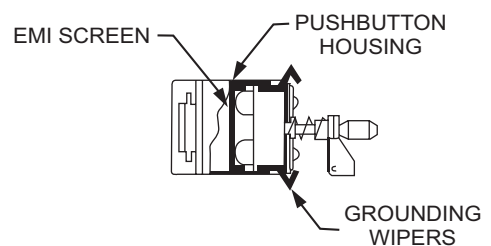



INSTALLATION PROCEDURE (Single Unit)

1. Extract pushbutton.
2. Rotate locking screws inside housing counter clockwise with small screw driver.
3. Slide mounting sleeve off of unit.
4. Install unit through front of panel with the word "TOP" to top of the panel.
5. Slide mounting sleeve onto back of unit.
6. Rotate locking screws clockwise to bring mounting cams to lock position. Mounting torque is 3/4 to 1.0 inch pounds.
7. Insert keyed pushbutton.
8. Panel spacer P/N 50399 is to be used with a Mil-P-7788 edge-lit panel. The spacer goes between the subpanel and the switch bezel. If an edge-lit panel is not used the spacer may be placed behind the mounting panel and in front of the mounting sleeve.

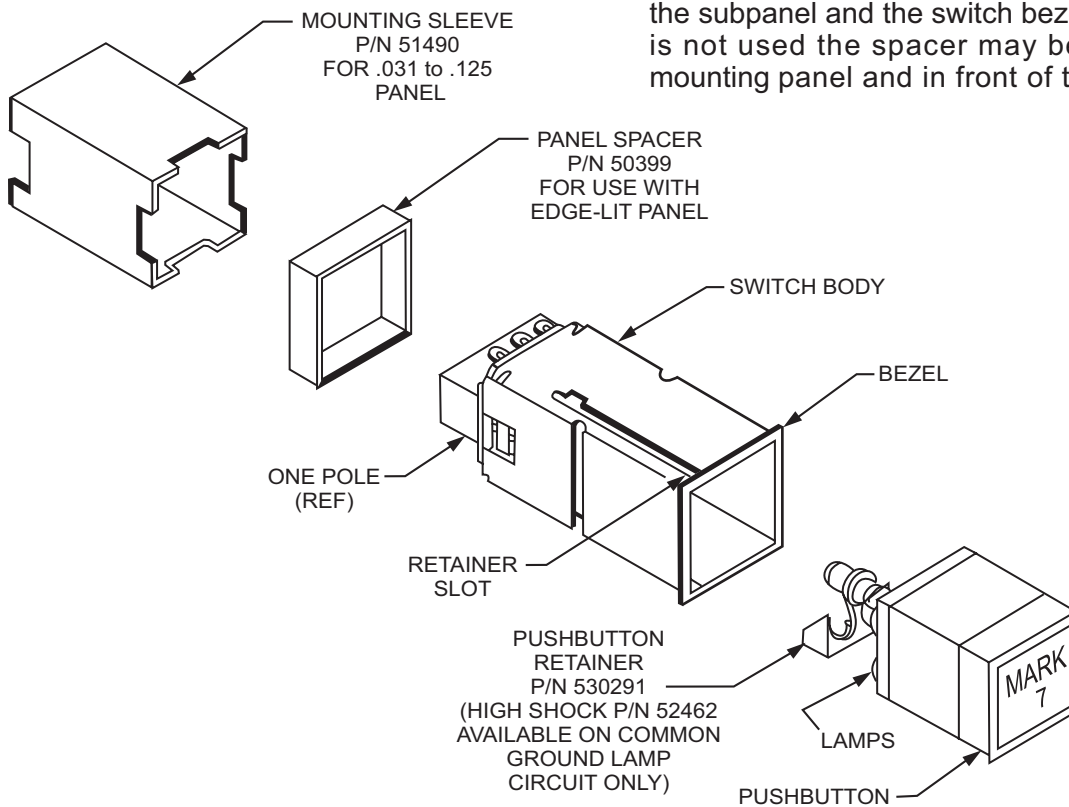

**INSTALLATION PROCEDURE
(Matrix Assemblies)**

1. Matrix mounts to back of panel.
2. Mounting brackets to customer specification.
3. Units may be ordered as assembled matrixes or individual switches and brackets.

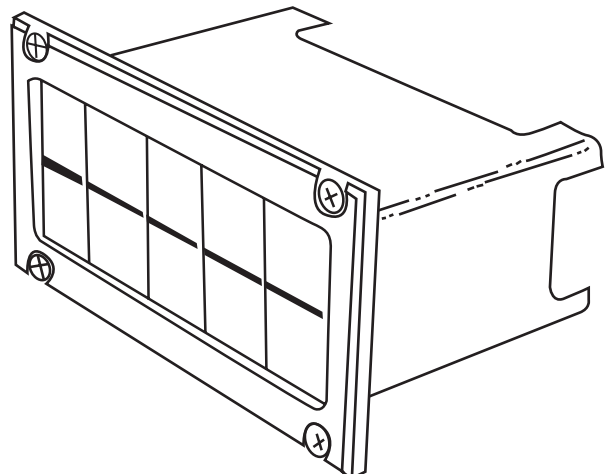



MAJOR OUTLINE DIMENSIONS INTEGRAL SEALED UNITS - Single station only

PUSHBUTTON STYLES (SEALED)

Splashproof per Mil-Std-108

B

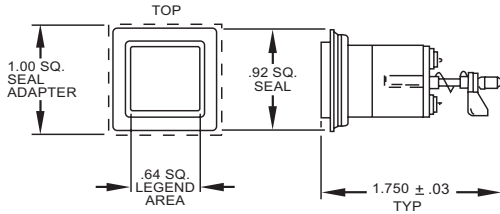

C

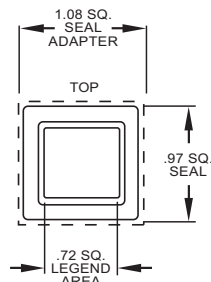

D

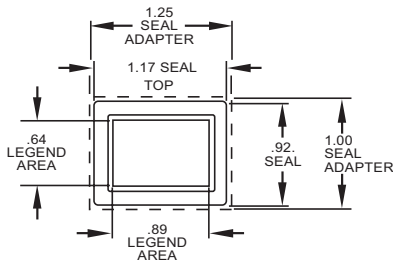

E

See page 13

Mounting hole size (Single Unit)

"B" Style Pushbutton : $.927^{+.010}_{-.000}$ SQ.

"C" Style Pushbutton : $.990^{+.010}_{-.000}$ SQ.

"D" Style Pushbutton : $.927^{+.010}_{-.000}$ X $1.180^{+.010}_{-.000}$

Note: All mounting hole have to have .062 corner radius.

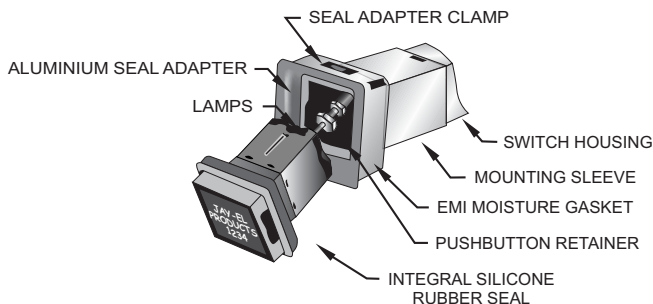

ACCESSORIES

Switch Guard for use with "B" pushbutton.
P/N 51034-1 (NO EMI) -2 (EMI)

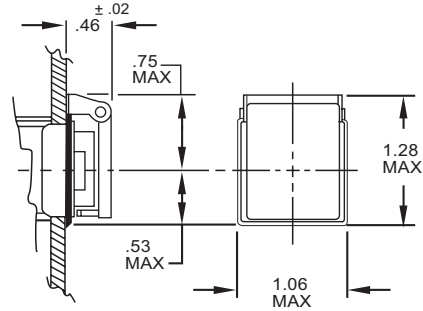

Switch Guard for use with "C" pushbutton.
P/N 51059-1 (NO EMI) -2 (EMI)

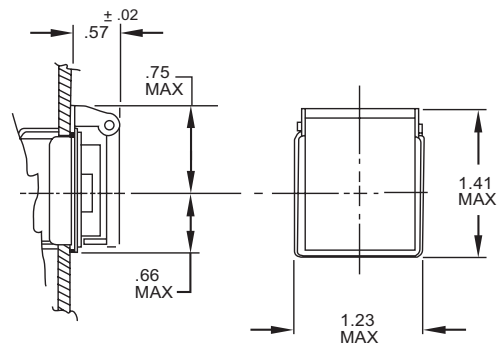

Switch Guard for use with "D" pushbutton.
P/N 50937-1 (NO EMI) -2 (EMI)

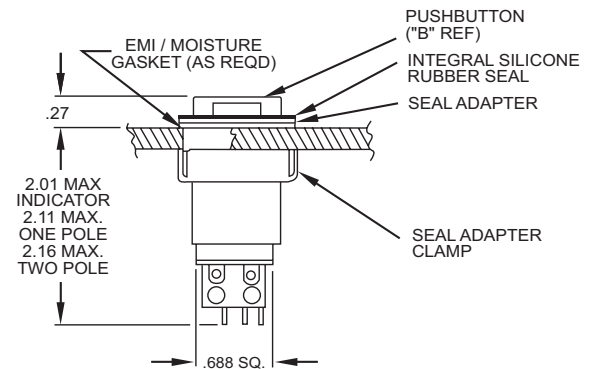
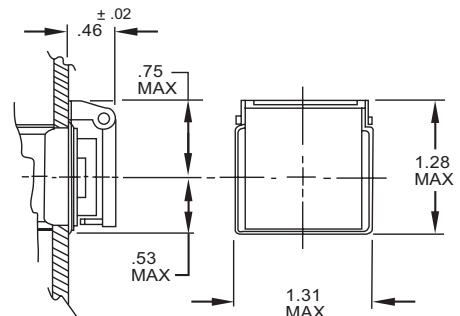

Tolerances: Unless otherwise specified - Fraction $\pm 1/32"$,
.XX $\pm .01$, XXX $\pm .005$



MAJOR OUTLINE DIMENSIONS, SEALED MATRIX

Matrix Mounting - Units will mount in panels of .031 to .250 thick.

Example: 2 x 2 "D" style, sealed pushbutton panel cutout dimension shown.

"C" style mounting center dimensions are 1.00 typical (2 places)

"B" style mounting center dimension is .94 typical (2 places)

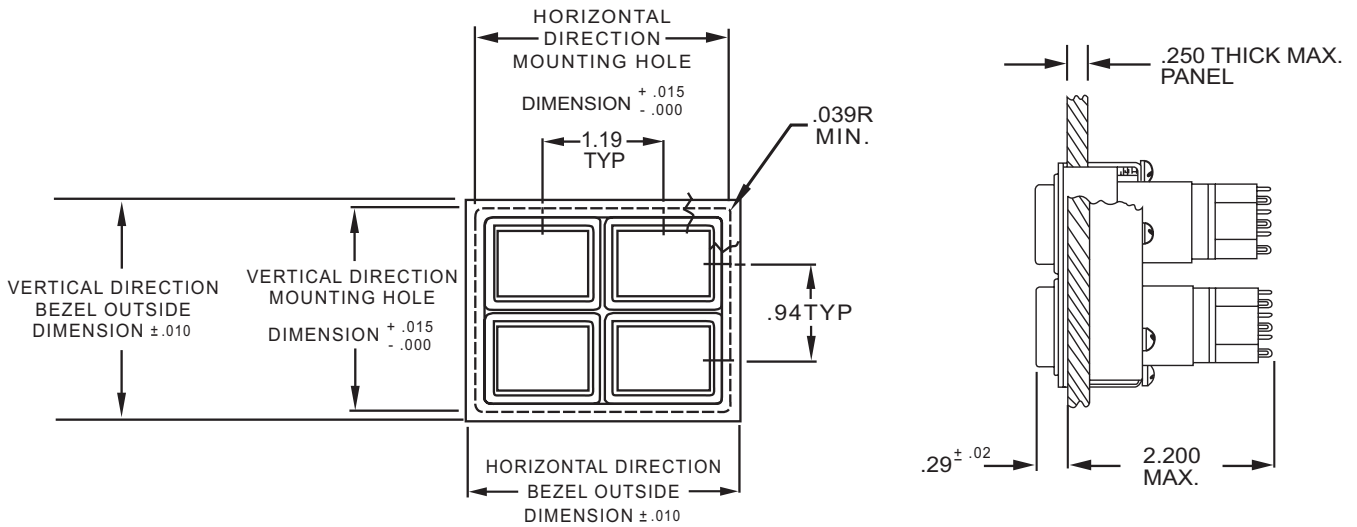

Panel cutouts and mounting centers for single and matrix units.

Note: When ordering matrices, contact Jay-El for part numbers.

HORIZONTAL DIRECTION										
Number of Positions	1	2	3	4	5	6	7	8	9	10
Mounting Hole Dim.										
B Style P/ B	1.062	2.002	2.942	3.882	4.882	5.762	6.702	7.642	8.582	9.522
C Style P/ B	1.122	2.122	3.122	4.122	5.122	6.122	7.122	8.122	9.122	10.122
D Style P/ B	1.312	2.502	3.692	4.882	6.072	7.262	8.452	9.642	10.832	12.022
Bezel Outline Dim.										
B Style P/ B	1.240	2.180	3.120	4.060	5.000	5.940	6.880	7.820	8.760	9.700
C Style P/ B	1.300	2.300	3.300	4.300	5.300	6.300	7.300	8.300	9.300	10.300
D Style P/ B	1.490	2.680	3.870	5.060	6.250	7.440	8.630	9.820	11.010	12.200
VERTICAL DIRECTION										
Number of Positions	1	2	3	4	5	6	7	8	9	10
Mounting Hole Dim.										
B Style P/ B	1.062	2.002	2.942	3.882	4.822	5.762	6.702	7.642	8.582	9.522
C Style P/ B	1.122	2.122	3.122	4.122	5.122	6.122	7.122	8.122	9.122	10.122
D Style P/ B	1.062	2.002	2.942	3.882	4.822	5.762	6.702	7.642	8.582	9.522
Bezel Outline Dim.										
B Style P/ B	1.240	2.180	3.120	4.060	5.000	5.940	6.880	7.820	8.760	9.700
C Style P/ B	1.300	2.300	3.300	4.300	5.300	6.300	7.300	8.300	9.300	10.300
D Style P/ B	1.240	2.180	3.120	4.060	5.000	5.940	6.880	7.820	8.760	9.700



"E" PUSHBUTTON:

Meets Splash Proof requirements with close mounting centers.

Integral seal for closest mounting centers of .875.

Sealed pushbutton designed to mount flush with light plate.

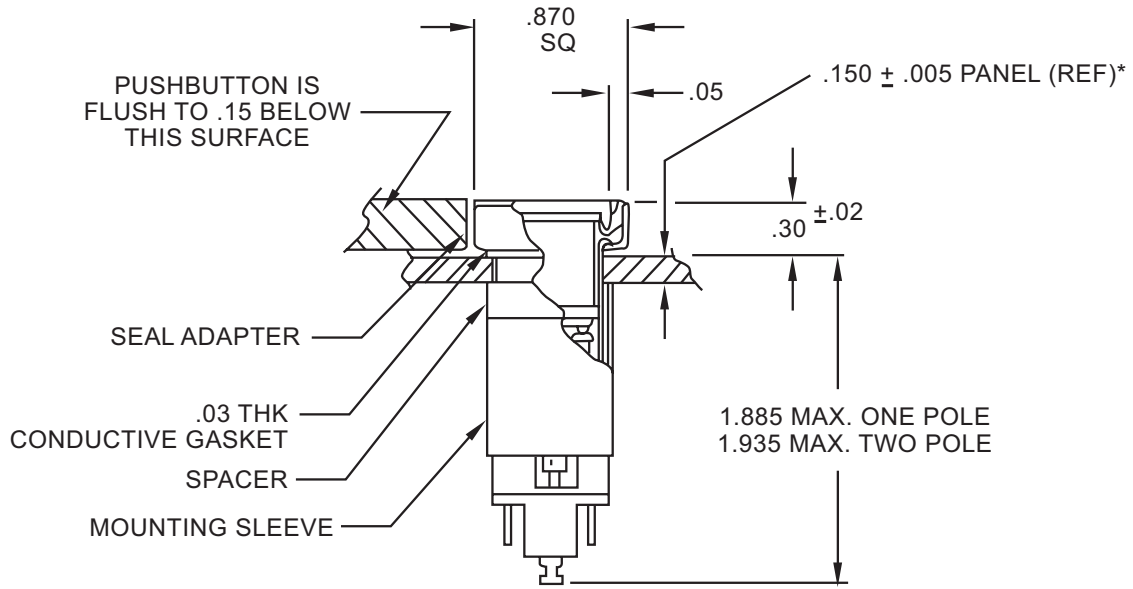

Switch body showing "E" style pushbutton mounting configuration.

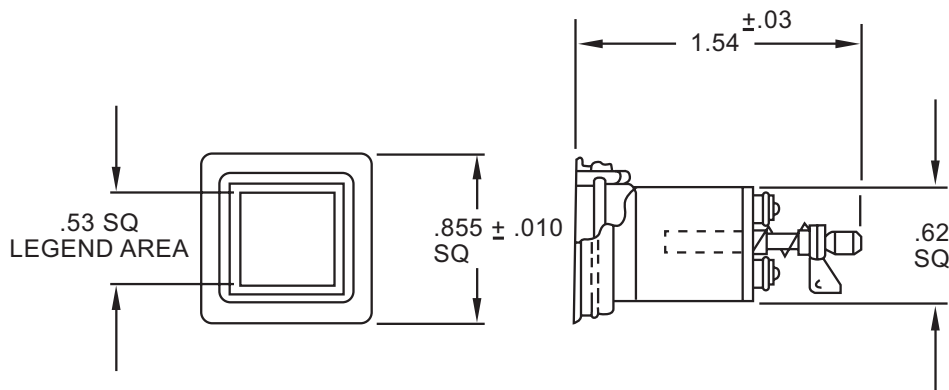

Pushbutton with seal detail.

Character information Ref: Page 10

*Note: Panel thickness must be specified to determine mounting sleeve length.

Contact Jay-El for ordering information.

Tolerances: Unless otherwise specified - Fraction $\pm 1/32"$, .XX \pm .01, XXX \pm .005

CHARACTER INFORMATION

(HORIZONTAL DIRECTION ONLY)

** To obtain more characters per line other type fonts are available.
Contact Jay-El for further information.

PUSHBUTTON STYLE	LEGEND SEGMENTS				CHARACTERS PER LINE			NUMBER OF LINES	
					SEGMENT	SEGMENT	SEGMENT	SEGMENT	SEGMENT
	CONDENSED BLOCK	SIZE	STROKE	HEIGHT	-1	-2-3	-4-5-6	-1-4-5	-2-3-6
<p>.53 SQ. LEGEND AREA</p> <p>STANDARD .62 SQ.</p> <p>A</p> <p>.62 SQ.</p>	JAY-EL PRODUCTS INC.	-1	.010	.072	8	8	3	5	2
	JAY-EL PRODUCTS INC.	-2	.012	.087	7	7	3	4	2
	JAY-EL PRODUCTS INC.	-3	.015	.109	6	6	3	3	1
	JAY-EL PRODUCTS	-4	.018	.125	5	5	2	3	1
	JAY-EL PRODUCTS	-5	.020	.145	4	4	2	3	1
	JAY-EL PRODU	-6	.025	.175	4	4	1	2	1
	JAY-EL PRO	-7	.035	.222	3	0	1	2	0
	JAY-EL P	-8	.040	.290	2	0	0	1	0
<p>.48 LEGEND AREA</p> <p>*DISPAY TYPE 8 ONLY</p>	JAY-EL PRODUCTS INC.	-1	.012	.072	11	11	5	5	2
	JAY-EL PRODUCTS INC.	-2	.012	.087	9	9	4	4	2
	JAY-EL PRODUCTS INC.	-3	.012	.109	7	7	3	3	1
	JAY-EL PRODUCTS	-4	.012	.125	6	6	3	3	1
	JAY-EL PRODUCTS	-5	.012	.145	5	5	2	3	1
	JAY-EL PRODU	-6	.012	.175	4	4	1	2	1
	JAY-EL PRO	-7	.012	.222	3	3	0	2	0

*** BASIC INFORMATION**

Legend area .480 square for full face on all push button styles.

.230 x .480 for 1/2 section (may be used with combination of other Display Types.)

CHARACTER INFORMATION (Continued)

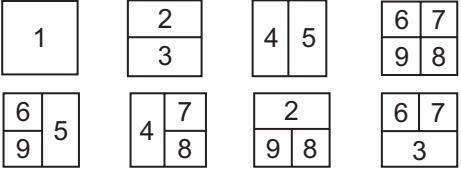
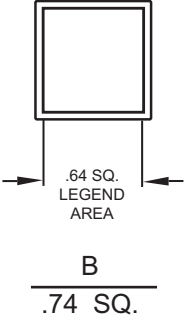
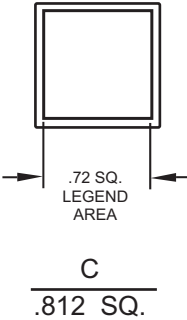
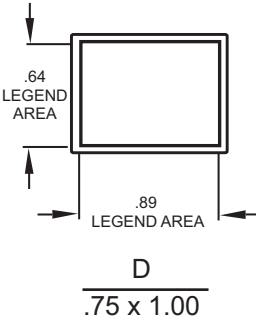
PUSHBUTTON STYLE	LEGEND SEGMENTS				CHARACTERS PER LINE		NUMBER OF LINES	
					SEGMENT	SEGMENT	SEGMENT	SEGMENT
	CONDENSED BLOCK	SIZE	STROKE	HEIGHT	-1-2-3	-4-5-6	-1-4-5	-2-3-6
 <p>B .74 SQ.</p>	JAY-EL PRODUCTS INC.	-1	.010	.072	10	5	5	2
	JAY-EL PRODUCTS INC.	-2	.012	.087	9	4	4	2
	JAY-EL PRODUCTS INC.	-3	.015	.109	7	3	4	2
	JAY-EL PRODUCTS	-4	.018	.125	6	3	3	1
	JAY-EL PRODUCTS	-5	.020	.145	5	2	3	1
	JAY-EL PRODU	-6	.025	.175	4	2	2	1
	JAY-EL PRO	-7	.035	.222	3	2	2	1
	JAY-EL P	-8	.040	.290	3	1	1	1
 <p>C .812 SQ.</p>	JAY-EL PRODUCTS INC.	-1	.010	.072	12	6	6	3
	JAY-EL PRODUCTS INC.	-2	.012	.087	11	4	5	2
	JAY-EL PRODUCTS INC.	-3	.015	.109	8	4	5	2
	JAY-EL PRODUCTS	-4	.018	.125	7	3	4	2
	JAY-EL PRODUCTS	-5	.020	.145	6	3	4	1
	JAY-EL PRODU	-6	.025	.175	5	2	3	1
	JAY-EL PRO	-7	.035	.222	4	2	3	1
	JAY-EL P	-8	.040	.290	3	1	2	1
 <p>D .75 x 1.00</p>	JAY-EL PRODUCTS INC.	-1	.010	.072	16	8	5	2
	JAY-EL PRODUCTS INC.	-2	.012	.087	14	6	4	2
	JAY-EL PRODUCTS INC.	-3	.015	.109	11	5	4	2
	JAY-EL PRODUCTS	-4	.018	.125	9	4	3	1
	JAY-EL PRODUCTS	-5	.020	.145	8	4	3	1
	JAY-EL PRODU	-6	.025	.175	7	3	2	1
	JAY-EL PRO	-7	.035	.222	5	2	2	1
	JAY-EL P	-8	.040	.290	4	2	1	1



23301 Wilmington Ave., Carson, CA 90745 USA

Phone: (310) 513-7200 - FAX: (310) 513-0741

Federal Mfg. Code No. 08719